

# Carbon Fiber-Reinforced Carbon

Properties · Uses · Forms supplied

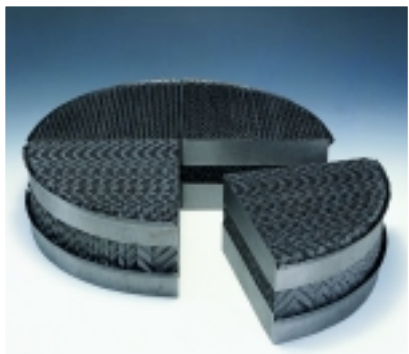
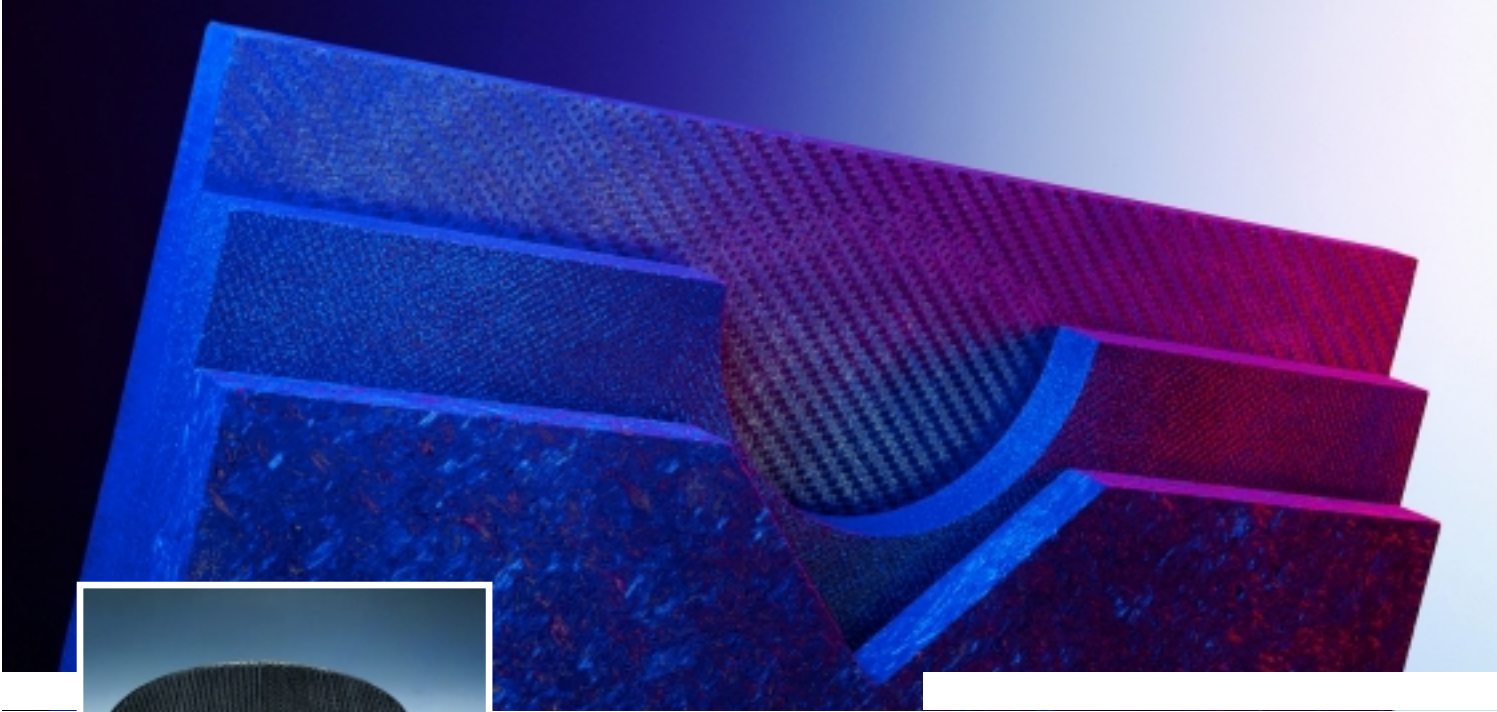

**SGL CARBON GROUP**

Graphite Specialties

**Contents**

**®SIGRABOND carbon fiber-reinforced carbon**

**The tailor-made composite material for extreme stresses** ..... **Page 3**  
**High-performance products fabricated from ®SIGRABOND for tomorrow’s industries** ..... **Page 4**  
**The most important ®SIGRABOND materials** ..... **Page 5**  
**Selected materials from a variety of production processes** ..... **Page 6**  
**Production scheme** ..... **Page 7**

**Properties of ®SIGRABOND**

**Thermal and mechanical properties of selected ®SIGRABOND materials** ..... **Page 8**  
**Chemical properties** ..... **Page 16**

**Applications of ®SIGRABOND**

**Furnace construction** ..... **Page 19**  
**Chemical process technology** ..... **Page 20**  
**Glass industry** ..... **Page 21**  
**High-tech applications** ..... **Page 22**

**Designing with ®SIGRABOND**

**Quality assurance** ..... **Page 23**  
**Machining** ..... **Page 23**  
**Design of components** ..... **Page 24**  
**Forms supplied and dimensions** ..... **Page 29**  
**Nomenclature** ..... **Page 31**

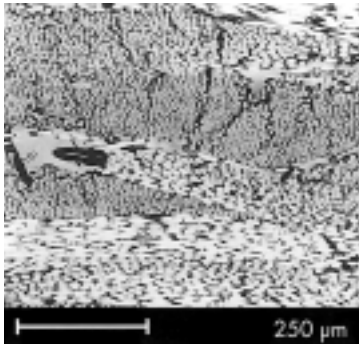

**1001**

\*SIGRABOND is the trade name used by SGL Carbon for a high-strength composite material consisting of a carbon or graphite matrix with carbon fiber reinforcement. This combination of carbon or graphite with carbon fibers unites the many and varied favorable material properties of fiber composites with those of electrographite.

**The tailor-made composite material for extreme stresses**

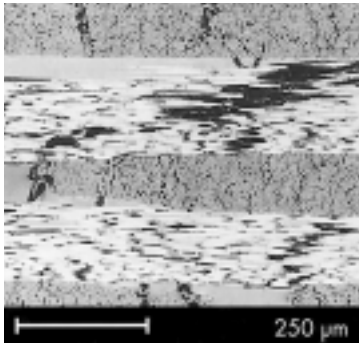

**1601**

- Heat resistance under protective gas up to temperatures in excess of 2000°C
- High specific strength and rigidity
- Low density and open porosity
- Low thermal expansion
- Extremely high resistance to thermal shock

**Characteristic properties**

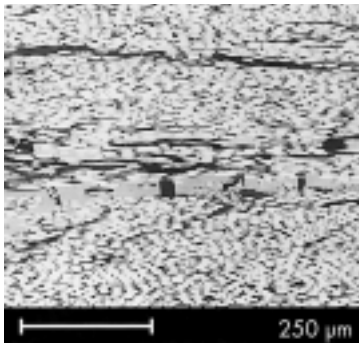

**2001**

- Electrical conductivity
- Anisotropy: in materials with aligned carbon fibers the flexural and tensile strength and also the electrical and thermal conductivity have different values parallel to the fiber from those perpendicular to the fiber or layer
- Excellent resistance to alternating loads, even at relatively high temperatures

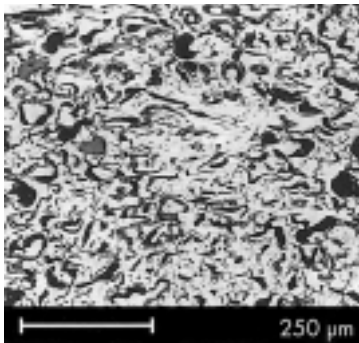

**3001**

- Pseudoplastic fracture behavior
- Corrosion resistance and resistance to radiation
- Production of high-purity grades possible

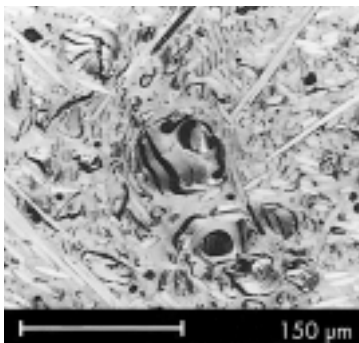

**4001**

**High-performance products  
fabricated from <sup>®</sup>SIGRABOND for  
tomorrow's industries**

**High-temperature technology**

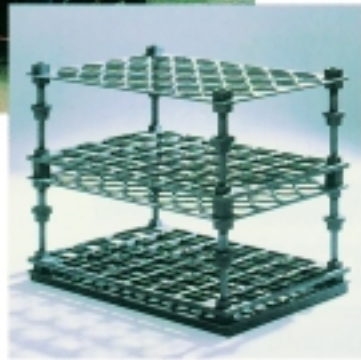

**Chemical industry**

**Hollow glassware industry**

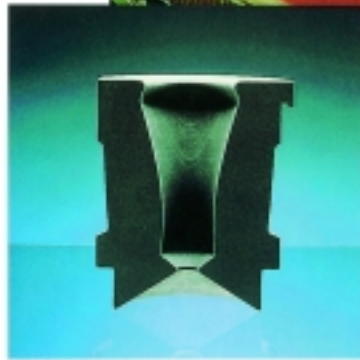

**High-tech applications**

**The most important  
® SIGRABOND  
materials**

*Table 1*

Material type	Type of fiber reinforcement	Standard fiber alignment*	Form	Preferred use, industry or product
<b>1001 G</b>	Staple fiber fabric	0° / 90°	Sheets	Furnace construction
<b>1501 G 1601 G 1701 G</b>	Roving fabrics	A: 0° / 90° B: 0° / ± 45° / 90°	Sheets and complex components	High-tech uses Glass industry Heating conductors
<b>2001 G 2302 G</b>	Wound rovings, reinforced	A: [(± 20°)2x (± 90°)1x]nx B: [(± 45°)2x (± 90°)1x]nx C: [(± 75°)2x (± 90°)1x]nx	Pipes, axially symmetrical hollow items	Molds for hot compression molding Heating conductors High-tech uses
<b>3001 G</b>	Felt	Random orientation	Sheets, blocks	Glass industry
<b>4012 G</b>	Chopped fibers	Random orientation	Sheets	Glass industry

\* 0° corresponds to the alignment of the warp fibers or the axis of rotation of a winding mandrel

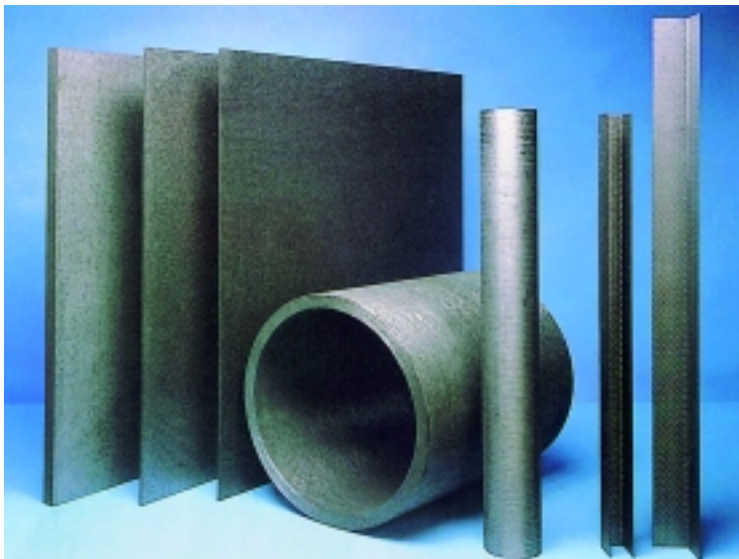

## Selected materials from a variety of production processes

The individual properties of ®SIGRABOND are determined by various factors, namely the type of fiber, fiber content, fiber arrangement, matrix materials layer build-up, densification, thermal treatment and any upgrading. Carbon fiber-reinforced carbon (CC) can thus be adapted to each individual profile of requirements or desired component design. Only the most important classes of raw material and process steps are shown in the production scheme opposite.

During the “green“ production stage liquid binders are applied to the various textile forms of the carbon fibers. In this operation the fiber is – if necessary – suitably aligned, the fiber/binder ratio is determined and the component is shaped. As it remains soft at this stage, the shaped component is then densified and hardened.

The thermal treatment steps involve baking at around 1000°C and graphitizing at up to 2700°C.

In the baking operation (also known as carbonizing) the volatile constituents are driven out of the binders, which are initially liquid until cured. What remains is a porous carbon matrix, which holds the carbon fibers together. To reduce porosity and increase both the strength and other properties, the baked material is then reimpregnated and baked again, in some cases repeatedly. The graphitizing process improves some of the composite material’s properties such as its electrical conductivity, thermal stability and resistance to both oxidation and corrosion.

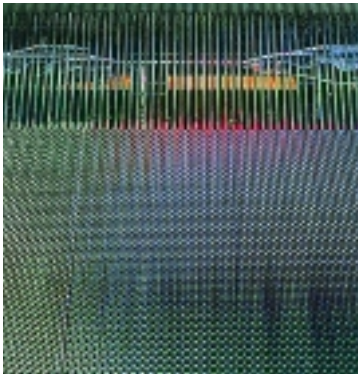

In the machining operation the workpieces are machined to the desired dimensions. A number of upgrading measures can also be carried out. In certain cases these considerably improve the utility value. Most ®SIGRABOND components are of monolithic design. Larger components, e. g. those for high-temperature furnaces, are held together by CC screws or bolts. Other jointing techniques can also be used.



## Production scheme

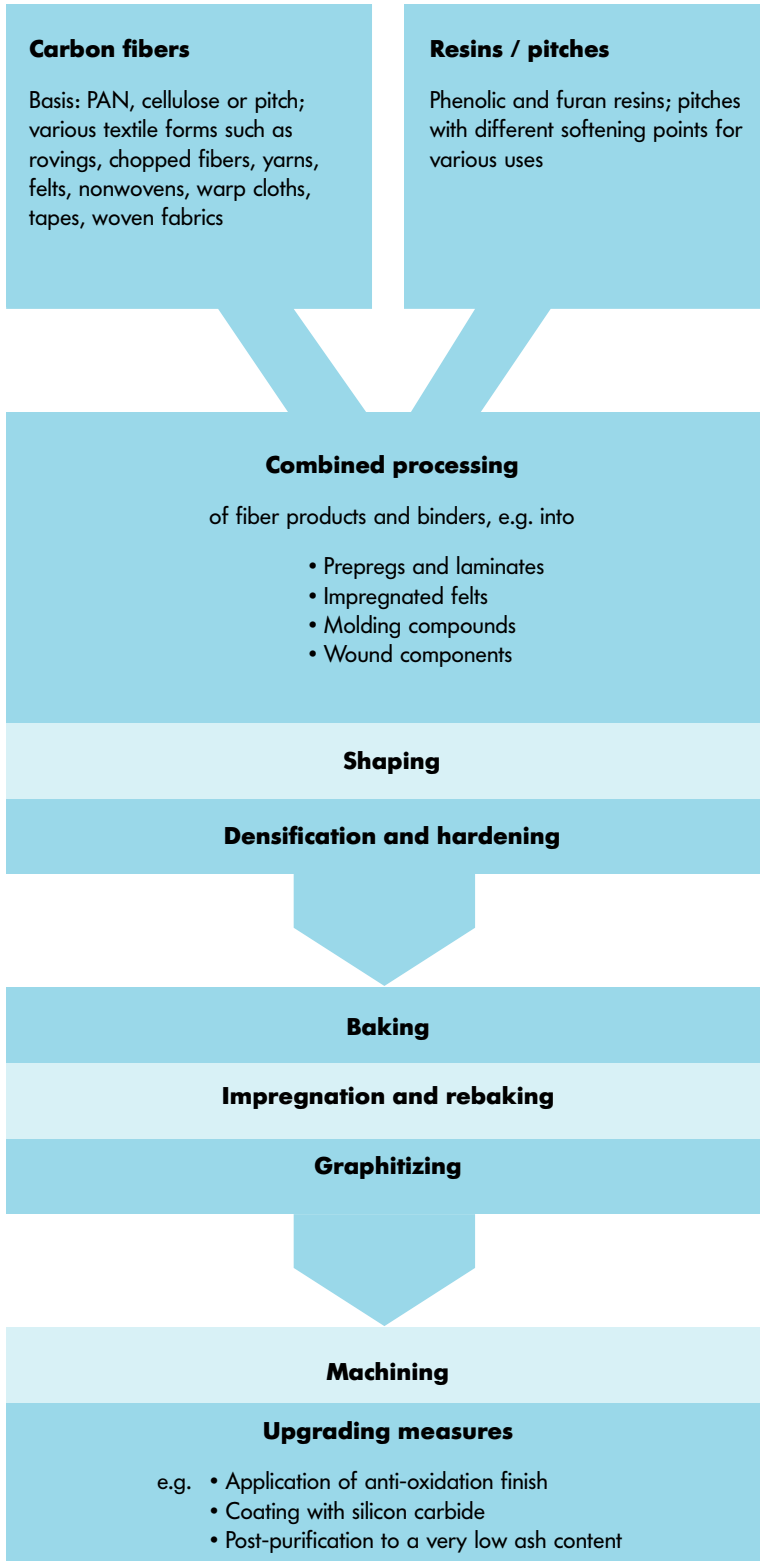

Raw materials



"Green" production



Thermal  
finishing stages



Final treatment

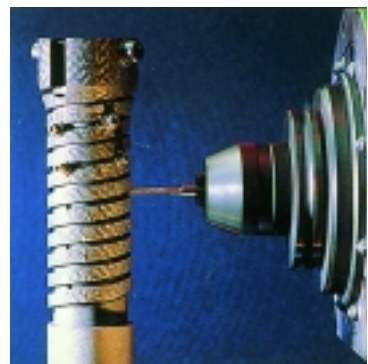

**Thermal and mechanical properties of selected ®SIGRABOND materials**

As the range of CC material variants that can be produced is very extensive, the data given in the following are only those for the most important applications and are confined to our ®SIGRABOND standard materials. Data relating to special mechanical characteristics, surface properties or stability are given for a few ®SIGRABOND grades by way of example.

In most high-temperature applications, use is made of CC materials treated at 2000°C whose properties appear in Table 2.

**Dependence of properties on the number of impregnations**

The change in the properties of the most important ®SIGRABOND grades as a function of the number of impregnation and rebaking operations is shown in Figure 1, exemplified by material grade 1601. The final stage is identical to that for standard grade 1601 G. As a general rule the material is found to improve in line with the number of densification (impregnation and baking) stages. A number of characteristic values such as interlaminar shear strength, flexural and tensile strength, bulk density, pore volume and Young’s modulus, are given by way of example. This improvement also extends to many other properties, including electrical and thermal conductivity, compressive strength and resistance to alternating loads. An increase in the number of densification stages, however, pushes up production costs.

**\*SIGRABOND 1601 densification**

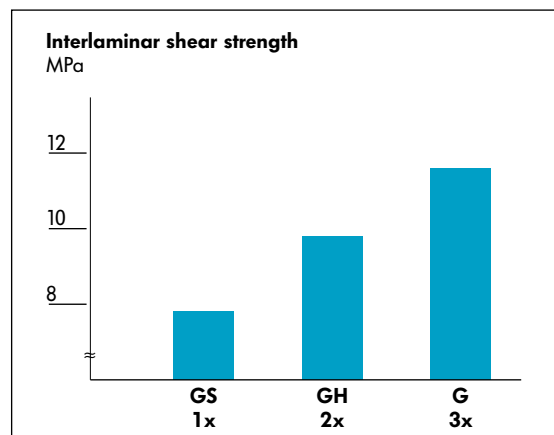
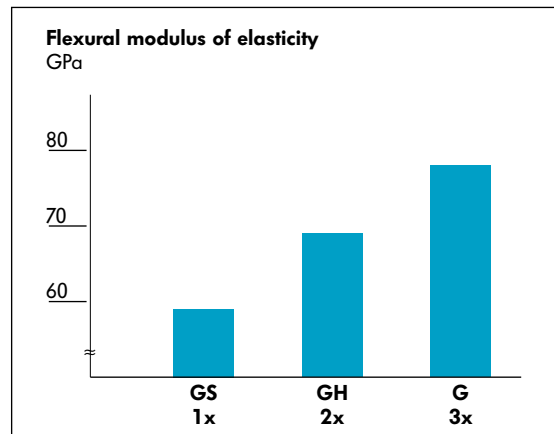
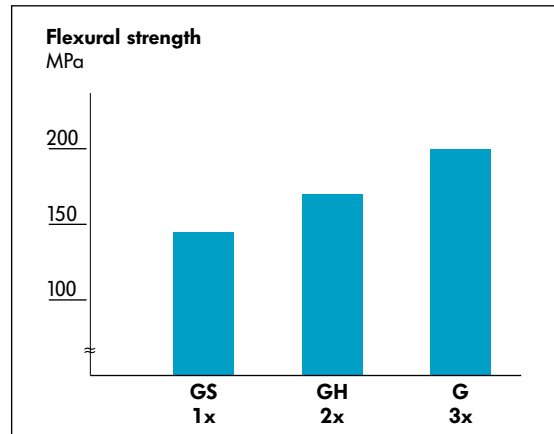
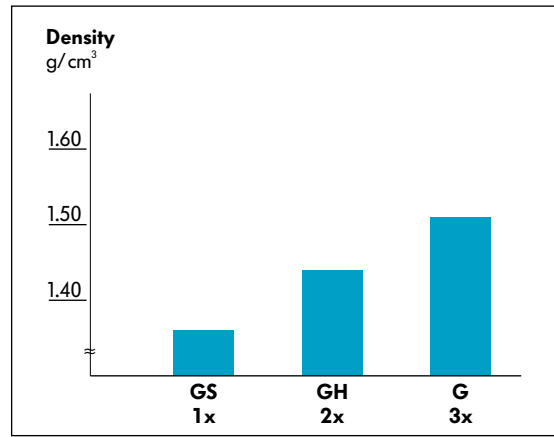

*Figure 1*  
Overall improvement in properties with the number of densification stages

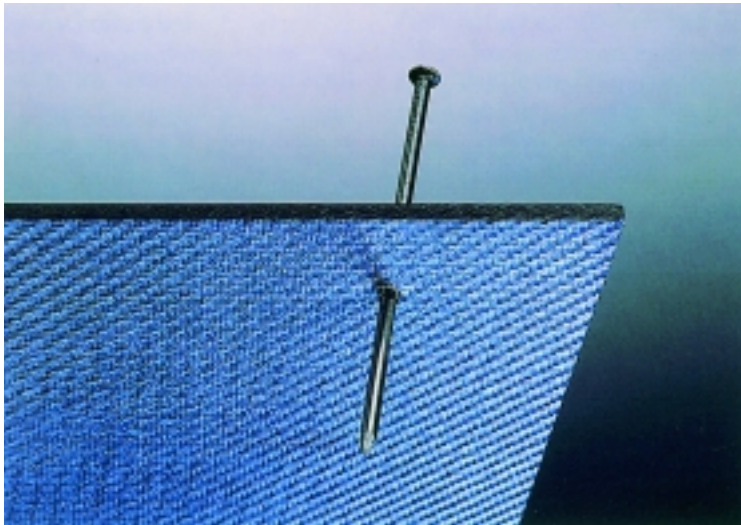

Table 2

**Typical values for the properties of graphitized <sup>®</sup>SIGRABOND**

Property*	Material type	1001 G	1501 G	1601 G	1701 G	2001 G <sup>1)2)</sup> 2302 G	3001 G	4012 G <sup>3)</sup>
Heat treatment	°C	2000	2000	2000	2000	2000	2000	2000
Bulk density	g/cm <sup>3</sup>	1.38 – 1.48	1.45 – 1.55	1.36 – 1.52	1.28 – 1.44	1.20 – 1.40	≈ 1.00	1.4 – 1.5
Porosity, open	%	18 – 25	10 – 12	11 – 15	n. d.	n. d.	n. d.	n. d.
Flexural strength, ⊥	MPa	110 – 130	240 – 300	150 – 220	140 – 180	30 – 70	≈ 30	35 – 40
Flexural modulus of elasticity,	GPa	28 – 33	70 – 85	60 – 80	60 – 70	15 – 25	≈ 10	20 – 25
Tensile strength,	MPa	55 – 65	320 – 400	300 – 350	280 – 350	n. d.	compressive strength ⊥ 20 - 25	compressive strength ⊥ 100 - 140
Resistivity at 20°C,	Ωμm	29 – 34	22 – 26	22 – 26	22 – 26	n. d.	25 – 30	-
Coefficient of permeability	cm <sup>2</sup> /s	7 · 10 <sup>-2</sup>	5 · 10 <sup>-2</sup>	0.3	-	n. d.	n. d.	-
Interlaminar shear strength	MPa	11 – 15	11 – 15	8 – 12	7 – 10	5 – 7	-	-

\* <sup>®</sup>SIGRABOND with standard laminate build-up or standard wind-up pattern

1) Layer build-up 2001 G: 0°C / ± 45° / 90°; build-up 2302 G, wound: roving and inner prepreg layer

2) Direction-dependent values: 0°; 90° values not shown

3) Trial product in the course of development

⊥ Measured perpendicularly to the plane of the laminate

|| Measured parallel to the plane of the laminate

n. d. = no data available

**Thermal and mechanical properties of selected SIGRABOND materials**

**Fracture behavior**

When placed under load, components made from fiber composites do not fracture suddenly but neither do they exhibit the plastic behavior of metals when these are stressed beyond the creep limit. Stresses imposed on CC cause only a few fiber strands to fracture at first, and only after repeated stretching does further failure occur. This type of fracture is known as quasi-plastic. Readers are also referred to details of effective bearing strength on page 27.

Because of its quasi-plastic behavior and porosity, CC can be secured by nails.

Figure 2 shows a typical stress-strain graph for CC materials, in this case SIGRABOND 1501 G. The maximum permitted load is achieved at an extension of around 0.3 %. The elongation of the material at fracture is between 0.7 and 1.0 %.

Figure 2

Typical failure behavior of a bending specimen of SIGRABOND 1501 G material

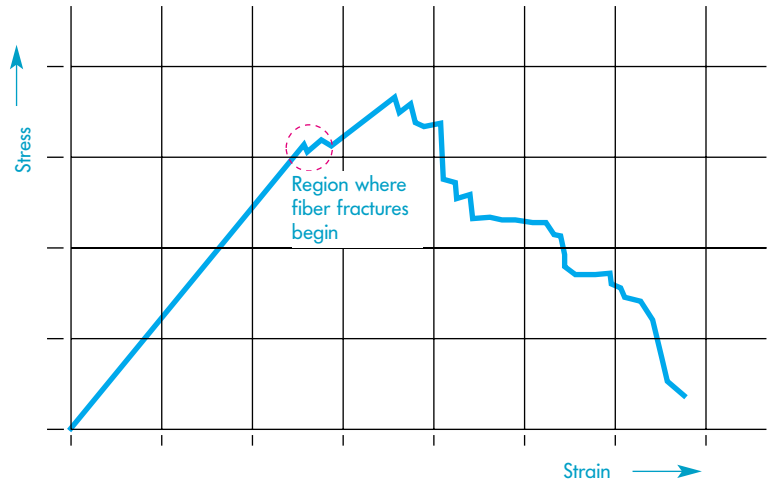

SIGRABOND’s transverse contraction number, like all its other properties, depends on the fiber content and alignment. Typical

values are given in the following table.

Table 3

Material type	Fiber alignment	Direction of measurement	Typical transverse contraction number
1001 G	0° / 90°	0°; 90°	0.15
1501 G	0° / 90°	0°; 90° 45°	0.01 0.65
1601 G	0° / 90°	0°; 90°	0.10
2001 G	0° / 90° 0° / ±45° / 90°	0°; 90° 0°	0.01 0.30

## Properties at high temperatures

The thermal treatment of \*SIGRABOND materials has the greatest influence on the physical properties of CC. It is even greater than that of other governing factors such as fiber content, fiber alignment and nature of the matrix.

## Hot bending strength

Unlike all other ceramic or metallic high-temperature materials, carbon-fiber materials increase in strength with a rise in temperature. At high

temperatures the materials are in a largely stress-free state. As they cool, the materials undergo a continuous build-up of internal stresses which are additional to any stresses imposed from outside. This results in low strength at room temperature but high strength at 1000°C or 2000°C, for example (Table 4).

It should be noted in regard to Table 4 that the rates of increase in strength from room temperature to elevated temperatures are lower for CC than for graphite. Compared with graphite, however, CC is 10 to 20 times stronger.

**Typical percentage changes in the hot bending strength values of selected carbons** *Table 4*

Material	20°C	1000°C	2000°C
*SIGRABOND 1001 G	100 %	+ 20 %	+ 40 %
*SIGRABOND 1501 G	100 %	+ 15 %	+ 30 %
Electrographites	100 %	+ 40 %	+ 85 %

## Specific electrical resistance

The characteristic paths of the curves for various grades of material are shown in Figure 3. The curves are unaltered by repeated heating. The highly graphitized material grade 1501 Z has the lowest specific electrical resistance.

Tubes with different wind-up patterns have very different specific electrical resistance values even if other production parameters are identical, e.g. number of densification processes and treatment temperature. The less the fibers are aligned with the axis of the pipe, the higher is the resistivity.

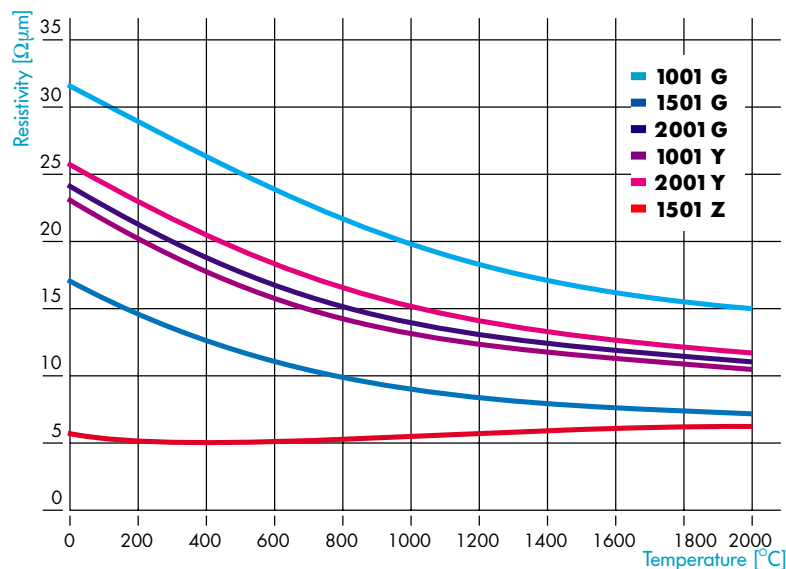

- Example from Figure 5 for RT and pipes with  $\pm 20^\circ$  winding:  $24 \Omega\mu\text{m}$
- Example for RT and pipes with  $\pm 75^\circ$  winding: approx.  $100 \Omega\mu\text{m}$
- Tubes with wind-up pattern  $[(\pm 20^\circ)_{2x} (\pm 90^\circ)_{1x}]_{nx}$

### Thermal and mechanical properties of selected ®SIGRABOND materials

Figure 4  
Linear coefficient of thermal expansion ( $\alpha$ ) of various ®SIGRABOND sheet materials

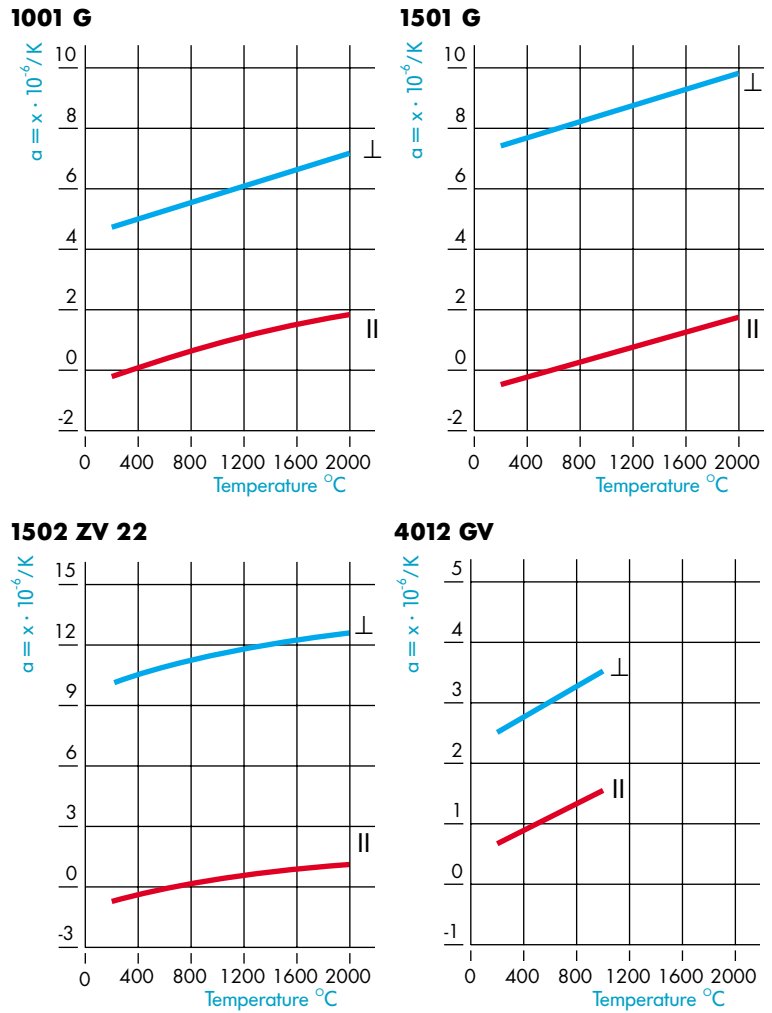
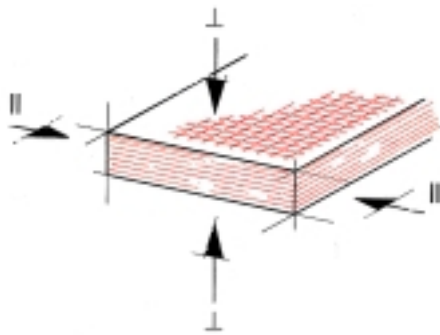
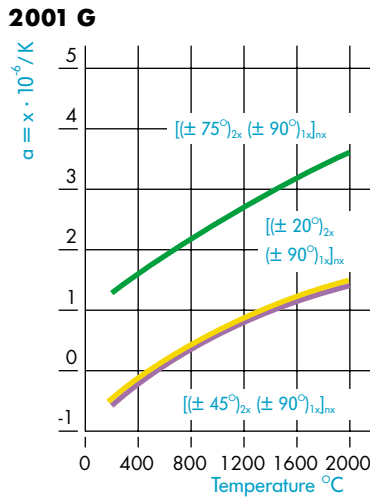

Figure 5  
Linear axial coefficient of thermal expansion ( $\alpha$ ) of ®SIGRABOND pipes with various fiber alignments



#### Coefficient of thermal expansion

The carbon fiber's anisotropy is reflected in the characteristic thermal data of composite sheets reinforced with 2D fabric. The high thermal conductivity determined in the fiber axis results in  $\lambda$  values between

50 and 180 W/m·K within the plane (II). The values reached perpendicularly to the plane (I) are between 5 and 30 W/m·K. Fabric-reinforced ®SIGRABOND materials with 260 W/m·K and unidirectionally reinforced materials with up to 500 W/m·K (at RT) have been developed for a nuclear fusion plant by modifying the production process for these materials. A crucial factor in these production processes is the formation of well-defined graphitic structures.

The characteristic paths of the curves for various material grades are given in Figure 4. If the coefficients of thermal expansion of a standard sheet are measured in the plane of the sheet but at an angle to the warp fiber direction rising from 0° to 90°, the values alter only slightly.

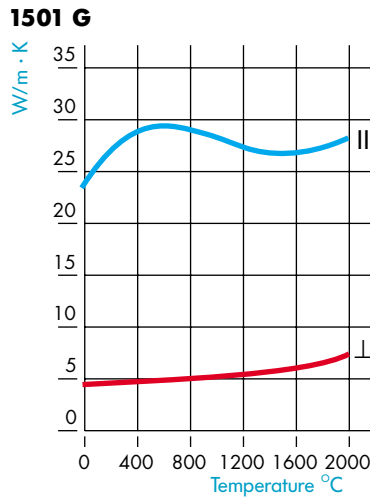
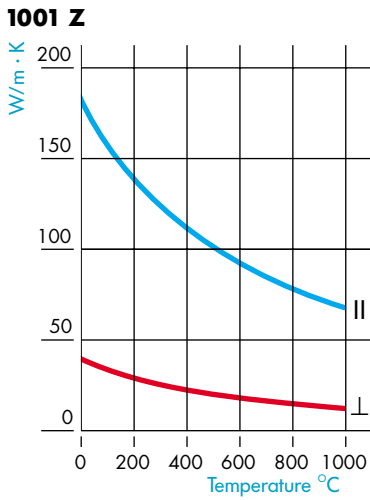
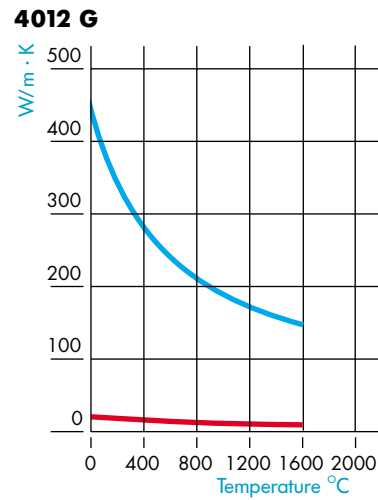
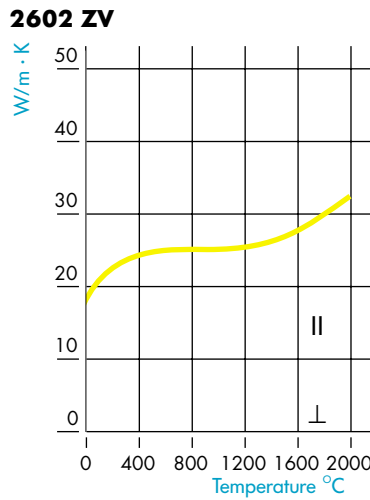
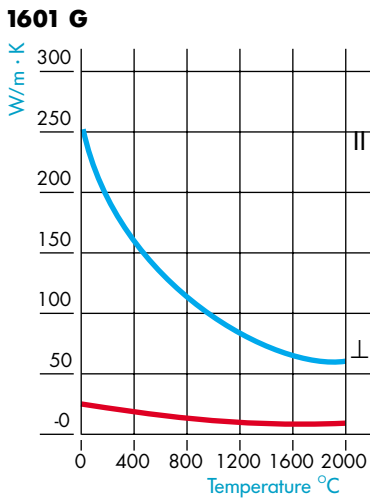

Figure 6  
Thermal conductivity of various <sup>®</sup>SIGRABOND grades



The axial coefficients of thermal expansion of <sup>®</sup>SIGRABOND pipes with the three standard wind-up patterns are shown in Figure 5.

### Thermal conductivity

The thermal conductivity values of material grades with bidirectionally aligned fibers (woven fabrics) are usually between 5 and 150 W/m·K at room temperature (see Figure 6). <sup>®</sup>SIGRABOND materials with thermal conductivity up to 500 W/m·K at room temperature have been developed for a nuclear fusion plant by using ultra-high treatment temperatures and a matrix with a very well-formed graphite structure (see Figure 6/2002 ZV).

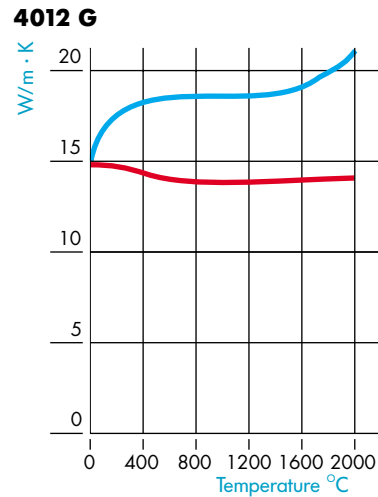

Figure 7  
Axial thermal conductivity of <sup>®</sup>SIGRABOND pipes

# Thermal and mechanical properties of selected ®SIGRABOND materials

## Dynamic strength

One special strong point of  
®SIGRABOND is its dynamic  
strength at high service temper-  
atures. After  $10^6$  to  $10^7$  load alter-  
nations the initial strength is found  
to have declined by only some 5 %  
(Figure 8).

Figure 8  
Fatigue in  
®SIGRABOND  
1501 G due to  
alternating load  
(plot of mean  
values)

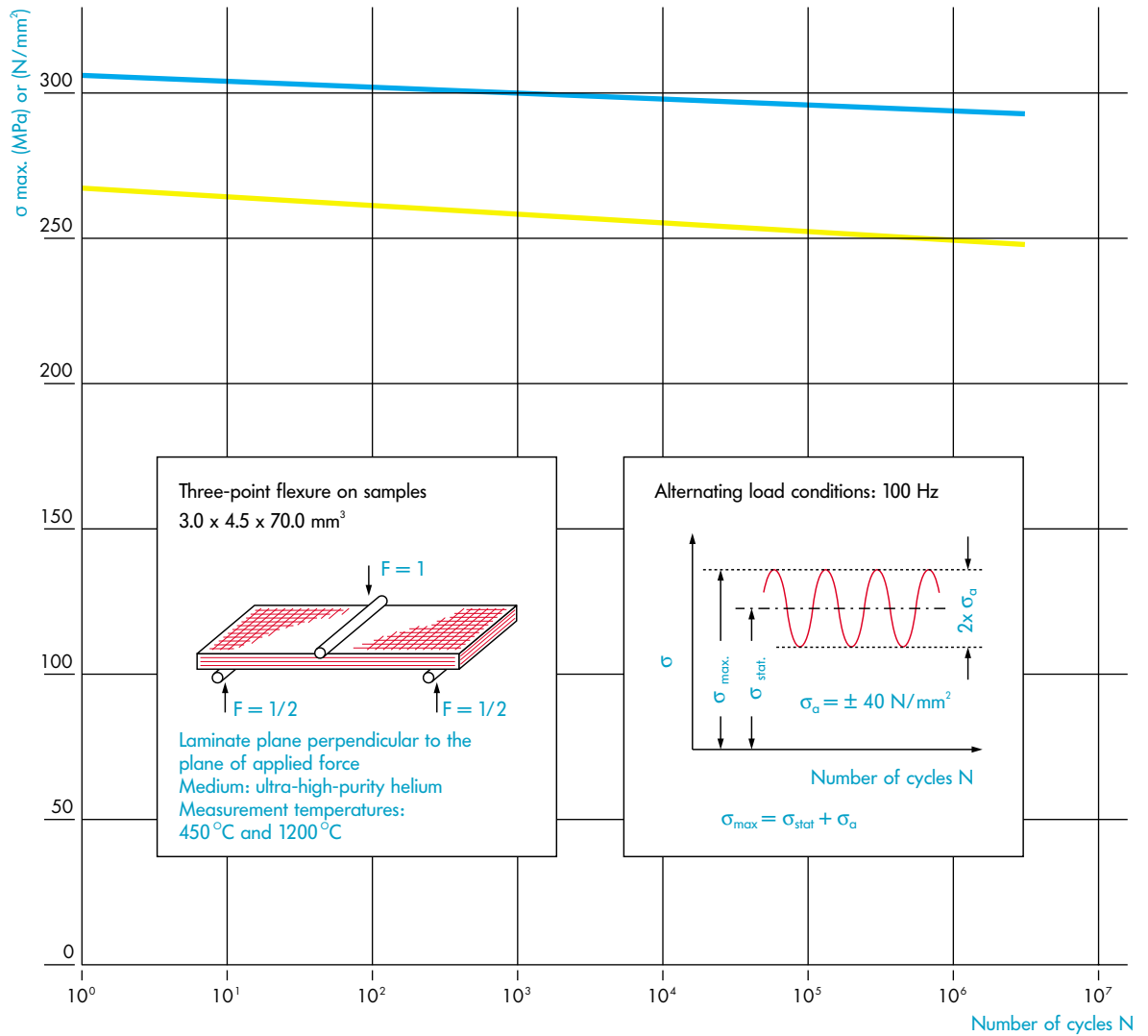

## Resistance to temperature fluctuations

Compared with most ceramic and metallic materials, \*SIGRABOND has superior resistance to fluctuations in temperature. This is the prerequisite for the successful use of this class of materials in high-temperature applications. The thermal shock behavior of homogeneous and crack-free materials is usually described by the “first” and “second” thermal stress parameters R and R<sup>1</sup> respectively.

$$R = \frac{\sigma_z(1-\nu)}{E \cdot \alpha} \quad R^1 = \frac{\sigma_z(1-\nu)}{E \cdot \alpha} \cdot \lambda$$

where

$\sigma_z$  tensile strength of the material  
 $\nu$  transverse contraction number  
 $E$  Young's modulus  
 $\alpha$  coefficient of thermal expansion  
 $\lambda$  thermal conductivity.

R has the dimension of a temperature and describes the maximum temperature difference that the respective body can still just tolerate in the thermal shock experiment.

R multiplied by the thermal conductivity gives R<sup>1</sup> with the dimension W/m·K. If typical material data, e. g. those for \*SIGRABOND 1501 G, are inserted into the above-mentioned equations, then, assuming that

$$\begin{aligned} \sigma_z &= 350 \text{ MPa} \\ E &= 75,000 \text{ MPa} \\ \nu_{0^\circ/90^\circ} &= 0.03 \\ \alpha_{11, 1000^\circ\text{C}} &= 0.3 \cdot 10^{-6} \text{ K}^{-1} \\ \lambda_{11, 1000^\circ\text{C}} &= 28 \text{ W/m}\cdot\text{K} \end{aligned}$$

this yields the values

$$\begin{aligned} R &= 15,000 \text{ K} \\ R^1 &= 422,000 \text{ W/m} \end{aligned}$$

As hairline cracks in a material dissipate the thermal stresses, materials with hairline cracks display good stability to temperature fluctuations. This is true of \*SIGRABOND. The equations given in the foregoing are only approximately applicable to composite materials. One outstanding example of the resistance of CC to thermal shock is that of rocket nozzles. On the start-up of a power unit the CC is heated up to more than 2000°C within about two seconds.

## Specific heat

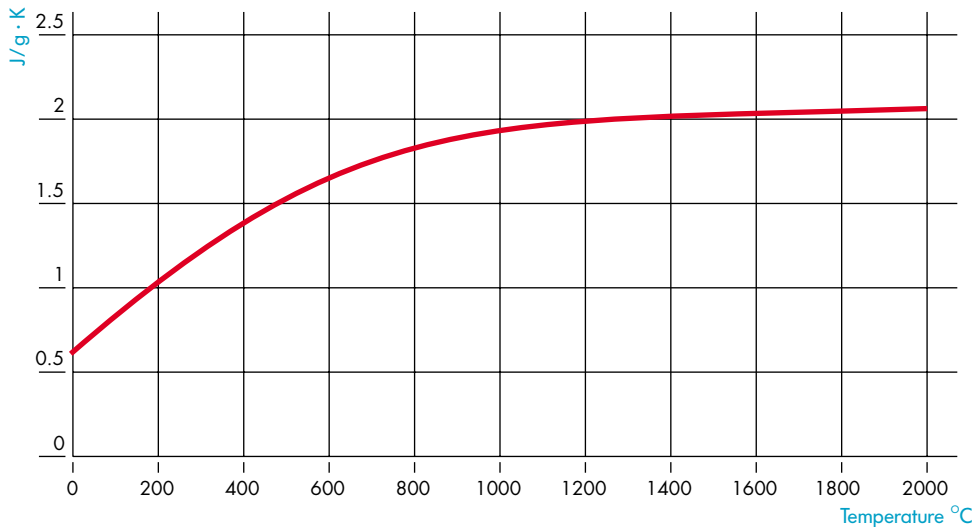

Figure 9  
 Specific heat of  
 \*SIGRABOND  
 1001 G

**Chemical properties**

**Purity**

Essentially, CC materials consist entirely of the element carbon. Other elements are present only as impurities introduced through the raw materials or production equipment employed. Exceptional purity is obtained in graphitized work-pieces, in other words components heated to well above 2000°C. At temperatures as high as this, many substances vaporize. Consequently, only a few unwanted elements remain behind in the graphitized \*SIGRABOND.

High purity is an advantage in the following applications:

- in the semi-conductor industry; the semi-conductors are not impaired by elements that readily vaporize
- in high-tech projects such as fusion reactor linings; pure \*SIGRABOND components have little effect on the quality of the fusion plasma.
- in chemical process equipment; the catalytic effect of the extraneous elements on oxidation and corrosion is minimized.

Typical ash contents and percentages of the commonest elements present in the ash quantities are set out in Table 5. The most important elements are calcium (Ca), iron (Fe), sodium (Na), phosphorus (P) and silicon (Si).

Table 5

Material category	.....G	.....ZR
Typical ash content in ppm	300 to 600	10 to 30
Element	Typical content in ppm	Typical content in ppm
Al	3 – 6	0.5 – 1.5
Ca	54 – 108	0.7 – 2.1
Fe	15 – 30	0.7 – 2.1
Na	30 – 60	1.6 – 4.8
Ni	*	0.4 – 1.2
P	45 – 90	*
Si	18 – 36	4.0 – 12
Ti	*	*
other	135 – 270	2.1 – 6.3

\* below detection limit

**Chemical resistance of  
\*SIGRABOND**

The graphitic nature of \*SIGRABOND makes it highly resistant to corrosive media. In Table 6 we have listed media that usually do not attack graphite.

\*SIGRABOND is not resistant to media with a powerful oxidizing action (e.g. nitric acid, chlorine bleaching solution and oleum), especially at elevated temperatures.

If \*SIGRABOND is going to be in contact with mixtures of substance

and if impurities are present, even in very small quantities, or if there are doubts about stability, the suitability of the chosen materials should be verified by testing.

Some metals, especially the transition metals such as iron, nickel and cobalt, though also silicon, form carbides at high temperatures in the presence of carbon.

Interstitial compounds may occur if certain molecules or atoms are included in the graphite lattice. Among these may be concentrated acids, halogens or halogenides.

Table 6

<b>Inorganic substances</b>	Hydrogen bromide, gaseous	Chlorobenzene	<b>Amines, nitro compounds, nitrites (CN compounds)</b>	Fumaric acid or maleic acid
<b>Acids</b>	Hydrogen chloride, gaseous	Chloroform	Aniline	Glycolic acid
Arsenic acid	Hydrogen sulfide	Dibromoethane	Aniline hydrochloride	Lactic acid
Boric acid	Phosgene	Dichlorobenzene	Cyanogen chloride	Linoleic acid
Fluorosilicic acid	Phosphorus oxychloride	Dichloroethane	Cyanuric chloride	Linolenic acid
Hydrobromic acid	Sodium thiosulfate	Dichloroethylene	Dimethyl aniline	Malic acid
Hydrochloric acid	Sulfur dioxide, gaseous	Ethyl chloride	Ethanolamine	Nicotinic acid
Perchloric acid	Thionyl chloride	Ethylene chlorohydrine	(mono-, di-, tri-)	Oleic acid
Phosphoric acid	<b>Organic substances</b>	Methylene chloride	Nitrobenzene	Palmitic acid
Sulfurous acid	<b>Aliphatic hydrocarbons</b>	Tetrachloroethylene	p-Nitrochlorobenzene	Propionic acid
Tetrafluoroboric acid	Heptane	Vinyl chloride	Nitrotoluene	Salicylic acid
<b>Salt solutions</b>	Hexane	<b>Alcohols, thioalcohols (mercaptans), phenols</b>	<b>Aldehydes, ketones</b>	Stearic acid
Acetates of all common metals	Kerosene	Amyl alcohol	Acetaldehyde	Tannic acid
Chlorides of all common metals	Mineral oil	Butanol	Acetone	<b>Esters</b>
Fluorides of all common metals	Naphtha	Ethanol	Chloral	Butyl acetate
Nitrates of all common metals	Pentane	Glycerine	Chloral hydrate	Butyl acrylate
Nitrites of all common metals	Petrol (gasoline)	Glycol	Formaldehyde	Ethyl acetate
Sulfates of all common metals	Synthetic petrol (gasoline)	Mannitol	Glyoxal	Isopropyl acetate
Sulfites of all common metals	<b>Aromatic hydrocarbons</b>	Methanol	Paraldehyde	Vinyl acetate and other esters of acetic acid
<b>Miscellaneous substances</b>	Benzene	Octanol	<b>Carboxylic acids</b>	<b>Miscellaneous compounds</b>
Ammonia	Toluene	Phenol	Acetic acid	Amino acids such as folic acid
Carbon disulfide	Xylene	Propanol	Acrylic acid	Carboxylic acid anhydrides such as acetic acid anhydride
	<b>Halogenated hydrocarbons</b>	<b>Ethers</b>	Benzoic acid	Organic sulfonic acids such as benzene-sulfonic acid
	Allyl chloride	Diethyl ether	Caprylic acid	toluene-sulfonic acid
	Carbon tetrachloride	Dimethyl ether	Chloroacetic acid (mono-, di-, tri-)	
		Isopropyl ether	Citric acid	
			Dichloropropionic acid	
			Formic acid	

## Chemical properties

### Oxidation behavior

®SIGRABOND is used mainly in a vacuum or protective gas. As no oxidizing gases are present, it does not oxidize.

Oxidation occurs in the presence of oxidizing gases at elevated temperatures. Its intensity is governed by the partial pressure of O<sub>2</sub> and also varies depending on the material type used. In air, oxidation begins on carbonized material at about 350 °C, and on graphitized CC at about 450 °C. The rate of oxidation depends also on the nature of the matrix carbon, the porosity, the catalytic effect of the impurities, the rate

of movement and composition of the surrounding gas – e. g. moisture content and other factors.

The resistance of ®SIGRABOND materials to oxidation is improved by impregnation with anti-oxidation agents or coating with silicon carbide (SiC).

### Protective coatings

Our company supplies ®SIGRABOND materials with hard SiC protective coatings (see photo below). The coatings adhere excellently to the CC and resist even high thermal and mechanical stresses.

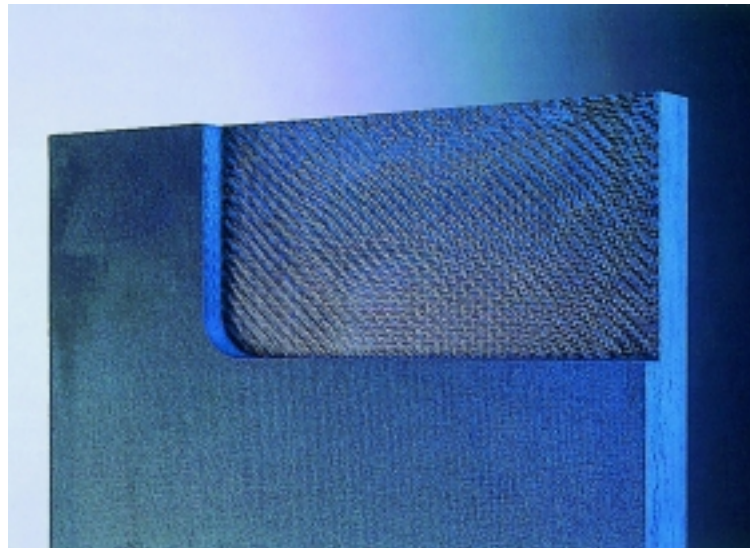

The following properties of CC make it especially suitable for use in furnace construction:

- Heat resistance and stability to thermal shock
- Low mass, allowing short heating and cooling times
- Strength, specific strength and fracture toughness
- Adjustable specific electrical resistance
- Low coefficients of thermal expansion; hence negligible thermal stresses

### Main uses

- Hard-metals sintering furnaces
- CVD furnaces
- Hot isostatic presses, hot presses
- Furnaces for high-temperature ceramics
- Plants for the production of ultra-high-purity silicon
- Vacuum and protective gas furnaces for hardening and carburizing steel

### Typical components and their advantages

- Heating elements for temperatures up to 2500°C; unlike brittle materials these allow thin-walled light-weight structures (photo upper right)
- Thin charging plates and mountings; saving in space, greater useful volume for products, e. g. hard-metals components
- Screws and threaded bolts with high fracture toughness; saving in weight; high-temperature strength (photo lower right)
- Pressure plates and female mold cavities for hot sintering presses
- Support structures and lining strips for graphite felts
- Good combination potential of <sup>®</sup>SIGRATHERM graphite insulating felts and <sup>®</sup>SIGRAFORM graphite components (photo left)
- Brochure on <sup>®</sup>SIGRABOND <sup>\*</sup>charging systems and heating elements in carbon fiber-reinforced carbon available on request

<sup>\*</sup>carbon fiber-reinforced carbon

### Components made from <sup>®</sup>SIGRABOND for furnace construction

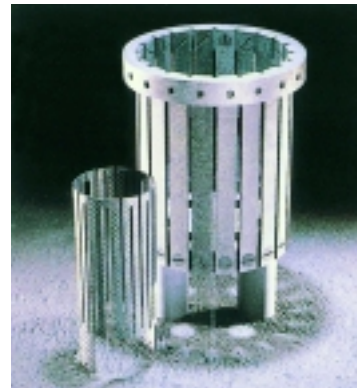

**®SIGRABOND  
components for  
chemical process  
technology**

The following properties of CC are important to its use in the chemical industry:

- Corrosion resistance at up to high temperatures
- Strength even in low-thickness components
- Resistance to vibration
- Electrical conductivity (in electrochemical processes)

**Examples of CC components**

- Structured packings for separation columns (European Patent No 0499040) (photo upper right)
- Stirrers and feed pipes (photo lower right)
- Support grids and other column internals (photo left)

**Advantages**

- Textile materials made from carbon fibers, e.g. mesh fabrics, can be used to produce **®SIGRABOND** materials with large open surfaces. CC packings made of such materials are highly effective in separating liquid mixtures in distillation-rectification plants.
- The properties of **®SIGRABOND** allow elegant design techniques to be used. Components like grids can be produced in lightweight designs which allow for dismantling. This enables maintenance work on columns to be carried out through manholes without the need to dismantle the entire column.
- For chemical resistance, see Table 6.

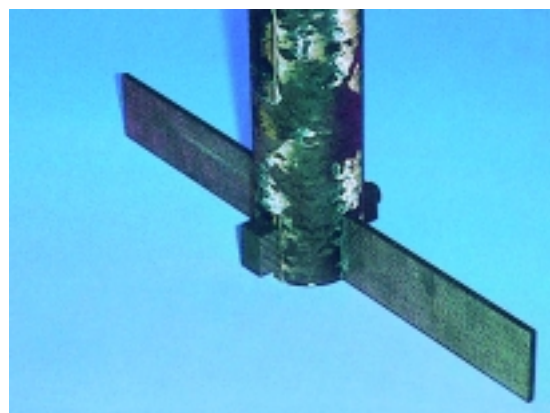
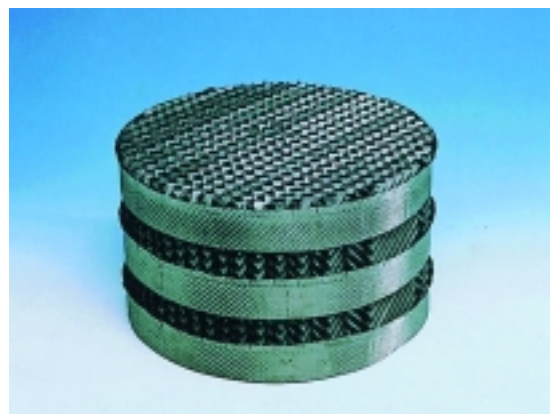
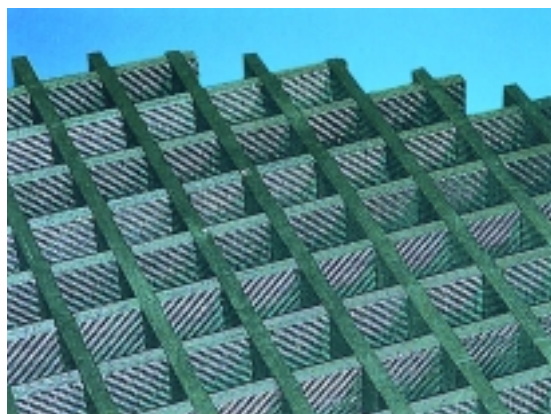

The following properties of CC are especially useful for applications in glassware manufacture:

- Stability to thermal shock, strength
- Unwettability by molten glass
- Low hardness and thermal conductivity; hence, no impairment of the glass surface
- Good porosity
- Impact toughness.

### Components produced include

- Channeling systems to carry the gobbets of molten glass during hollow glassware manufacture (photos left)
- Various contact element designs for moving hot hollow glassware articles and / or tubes (photo right)
- Molds for crystal and lead crystal drinking glasses (photo center).

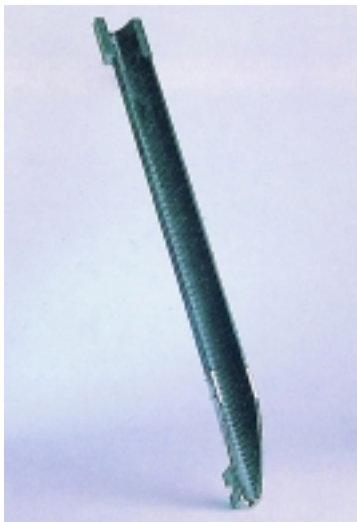

### Advantages of <sup>®</sup>SIGRABOND in glass component manufacture

- A CC channeling system needs no inner cooling like metal scoops, for instance; neither does it need treatment with short-lived paints or paste finishes or spray coating with oil.
- The low weight of a fast-moving scoop reduces the mass moment of inertia and lowers the stresses imposed on the gobbet distribution mechanism; moreover, lightweight troughs for the glass are easy to install and remove.
- The mechanical and thermal stability prevents plastic deformation of the scoop at the gobbet impact point and ensures long service life as well as low glass contamination from abraded carbon.
- The low thermal conductivity of the contact elements prevents rapid heat dissipation and thus avoids cooling cracks, even in sensitive products.
- For further details, see our technical information on hollow glassware production.

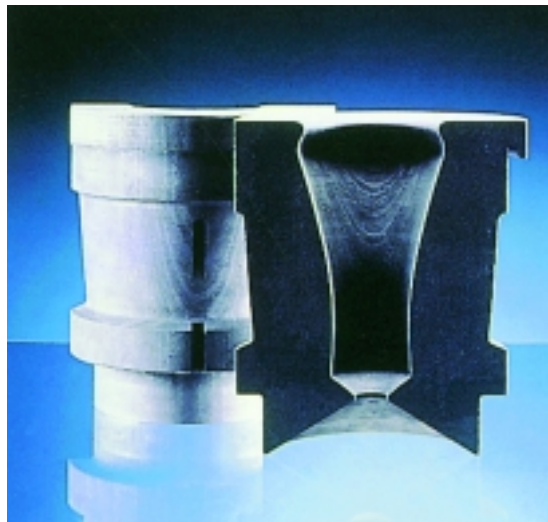

### Components made from <sup>®</sup>SIGRABOND for the glass industry



**®SIGRABOND  
components for  
high-tech applications**

CC material originated in aerospace projects. To successfully manufacture and use rocket nozzles and heat shields, for instance, the materials used must be

material exists which could be modified to give such a wide thermal conductivity range. ®SIGRABOND materials, however, can be adapted to give optimum solutions.

- extremely heat-resistant
- exceptionally stable to thermal shock and
- fracture-resistant.

CC meets these requirements excellently. Other important properties of CC are its

- vibration resistance
- low density and
- adjustable thermal conductivity.

The different high-tech applications demand high-performance materials with a wide variety of thermal conductivity values. A heat shield needs very low values, e.g. 5 W/m·K, whereas a protective “tile” in a fusion reactor requires values above 300 W/m·K. No isotropic base

**The following noteworthy components have been fabricated from ®SIGRABOND materials:**

- 5-meter form for the super-plastic shaping of titanium sheet at above 900°C
- cladding for rocket combustion chambers
- gas rudders and thrust deflectors for military aircraft (photo left)
- cladding elements for the Joint European Torus nuclear fusion reactor in the UK (photo upper right)
- expansion nozzle of a hypersonic propulsion unit (photo lower right).

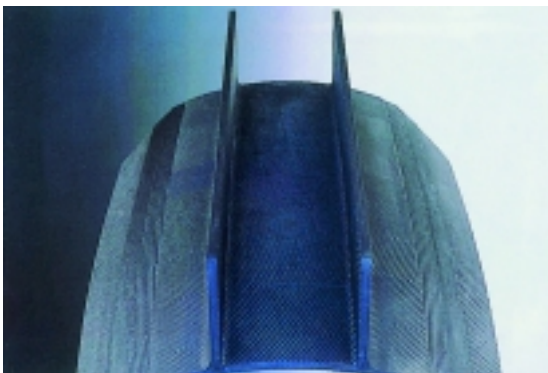

## Criteria for designing with CC materials

The design possibilities afforded by CC depend on the conditions of use, in particular high temperatures, the properties of the material and the

The individual production stages are fully documented in descriptions of manufacturing operations. The reproducibility of <sup>®</sup>SIGRABOND product quality is ensured by following these instructions in everyday working practice.

Semi-finished and finished products are monitored with non-destructive and destructive test methods. As both measuring techniques and test

<sup>®</sup>SIGRABOND is usually machined wet with hard-metals or diamond tools. If there are a large number of workpieces and their contours are suitable, water-jet cutting can also be recommended. SGL Carbon has many years' experience of machining carbon and graphite workpieces in all sizes, including very large dimensions. We can offer our customers the benefits of this experience. The carbonizing and graphitizing opera-

opportunities for shaping. <sup>®</sup>SIGRABOND is a frequent choice when peripheral conditions rule out the use of other materials for high-temperature furnace construction or chemical process technology.

methods are closely geared to practical conditions of application and followed meticulously, <sup>®</sup>SIGRABOND is highly reliable in use. As a relatively new class of material, CC is not yet used on a large scale.

Our aim is to supply customers worldwide with products and services of maximum benefit.

tions produce a form of skin on <sup>®</sup>SIGRABOND which is slightly denser than the materials beneath. The roughness depths of these outer skins are virtually identical, regardless of the material grade. When CC is machined (by turning, milling or grinding), the internal structure of the material is exposed. The roughness depths of such machined surfaces are less than those of the outer skins.

## Designing with <sup>®</sup>SIGRABOND

### Quality assurance

### Our commitment to quality

### Machining

**Typical roughness depths of <sup>®</sup>SIGRABOND materials in  $\mu\text{m}$**

	R <sub>Z</sub>	R <sub>a</sub>
Unmachined (outer skin)	40 to 50	10 to 20
Machined	25 to 40	5 to 15

Table 7

## Design of components

### Notable material properties

- Extreme thermal stability
- Sensitivity to oxidation
- High specific tensile strength and rigidity
- Low density
- Low interlaminar shear strength (ILS)
- Open porosity
- Quasi-plastic fracture behavior
- Anisotropic properties

### Hints on designing with ®SIGRABOND

- Choose a suitable ®SIGRABOND material grade to match known requirements or experience
- Aim to use monolithic, i.e. unitary construction and select shell-type or axially symmetrical or other component geometries produced by filament winding
- Use screw-type joints (no soldering, welding or bonding)
- Take advantage of SGL Carbon's experience in component design.

To comply with the foregoing points, the information and procedures given below should be noted and adhered to:

#### • Material grades

®SIGRABOND 1001, 1501, 1601, 1701, 2001, 3001 and 4001; depending on their letter suffix (see p.31) these material grades can be heat-treated up to 1000, 2000, 2200 and 2700°C. Special materials are possible such as ®SIGRABOND grades combining unidirectional layers and fabric layers in a composite material.

Figure 10

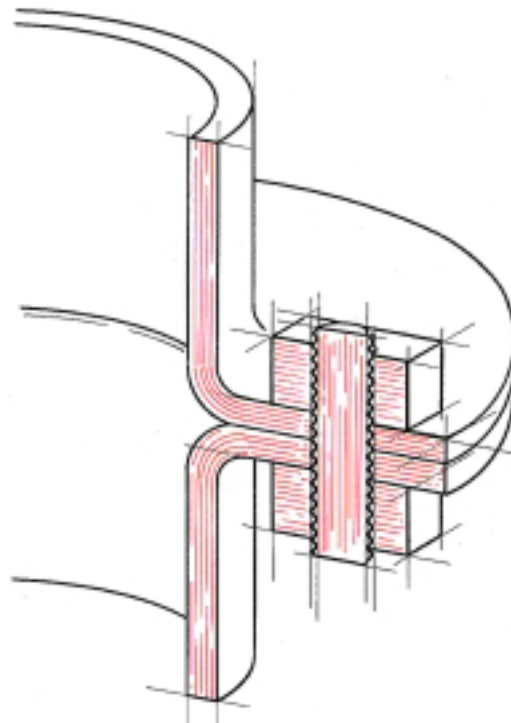

• **Monolithic designs**

The following points should be noted:  
The green production operations involve processing thin, large-surface-area semi-finished materials (woven fabric or unidirectional prepreg). The number of layers of semi-finished material will depend on the component design but should not be more than necessary; this will obviate the need to cut away excess layers later by machining, thereby damaging the supporting fibers. Allowance needs to be made during green production for localized thickening, narrowing or reinforcing ribs (see Figure 11).

Also employed in green production processes is a wind-up technique for high-strength structures (material grade 2001). This is normally used to produce components of axially symmetrical geometry or other geometries which are machined according to the same principles as shell-type/large-surface-area components. No components with long-fiber reinforcement (material grades 2001, 1501 and 1601) should include any curves in which the carbon fiber is bent through a radius of less than 3 mm. The use of compression molding for materials reinforced with chopped fibers (grades 3001 ad 4001) is an inexpensive green production method. Material grades 3001 and 4001 can be machined by cutting techniques without loss of strength.

Figures 11

*Typical thickened areas created by added layers, ribs of varying thickness and differences in the number of layers used*

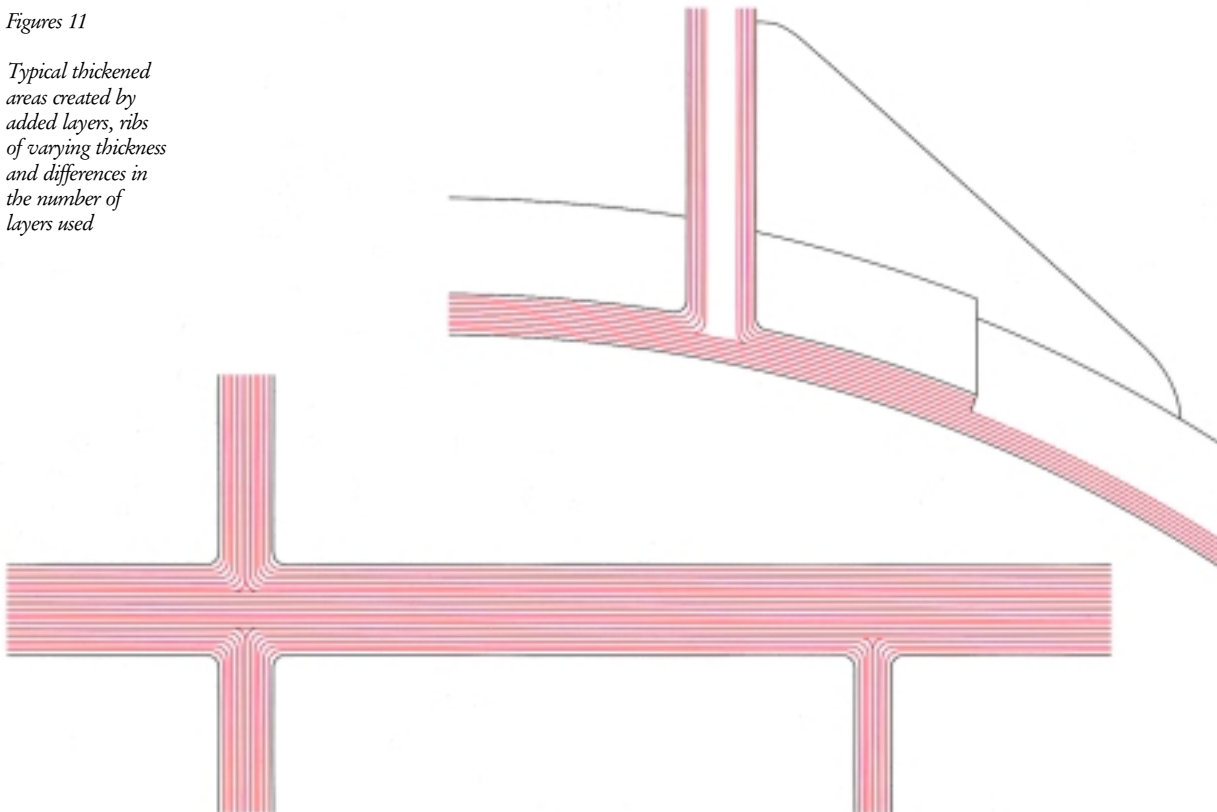

**Designing with  
®SIGRABOND**

• **Joints**

Joints of exceptional tensile strength can be formed with loop-shaped CC tensioning elements that utilize the high tensile strength of the carbon fibers efficiently and are tensioned with ®SIGRABOND wedges. The most usual method of producing effective joints, however, is with threaded bolts. The inherent anisotropy of the bolts needs to be allowed for. The alignment of the reinforcing layers in nuts, bolts

and screws is shown by the drawings in the section “Forms supplied“. As a rule, the reinforcing fibers in a screw joint connection, say, two CC sheets with CC screws are perpendicular to each other (see Figures 12 and 13). As long as the materials forming the joint are a suitable combination and if due regard is paid to component dimensions, bolt or screw design, assembly forces and the assembly instructions, then the resulting screw joints will perform reliably at up to 2000°C.

Figure 12

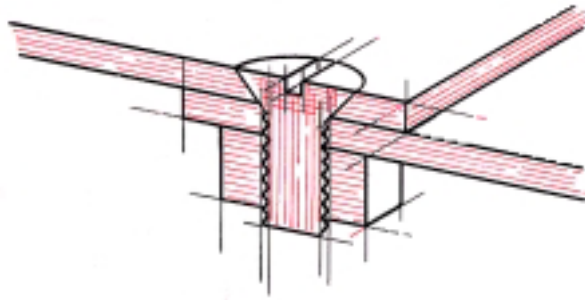
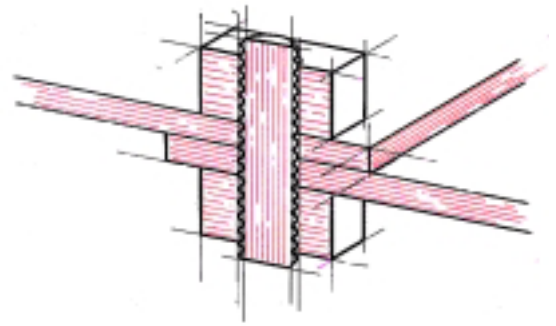

Figure 13



Examples of permitted tightening torques for bolts and screws with

metric threads are given in Table 8 below.

Table 8

**Permitted tightening torques for screws and bolts made from materials grades 1001 G and 1501 G**

M 8 to M 12	with hammer head	4.0 Nm
M 8 to M 12	with countersunk head	0.8 Nm

**Notes on tightening torques**

Bolts with hammer heads are used in all kinds of mechanical securing applications for CC components at extremely high temperatures.

Bolts with countersunk heads are preferred for the screw mounting of CC heating conductors because of the low electrical contact resistivity attainable and small space requirement.

If the tightening torques given above are greatly exceeded, the following typical forms of failure occur:

- torsional fracture of the bolt if the exposed thread length is relatively large, e.g. 50 mm with M 10
- stripping of the bolt thread if the exposed thread length on the bolt is short
- damage to the bolt head if bolts of the countersunk type are used.

• **Values for component design**

The tables (below) give values for various grades of <sup>®</sup>SIGRABOND material.

Two important factors in the design of components are the

- effective bearing strength values (see Table 9) and the
- shear strength values of bolts (see table 10).

Table 9

**Effective bearing strength values of various <sup>®</sup>SIGRABOND grades**

Material grade	Hole diam. [mm]	Tensile force in 0° direction		Tensile force in 45° direction	
		Pressure on hole face [MPa]	With relative widening of hole [%]	Pressure on hole face [MPa]	With relative widening of hole [%]
<b>1501 G</b>	5	90	2.3	80	2.7
	8	80	1.7	50	1.5
	10	70	1.5	30	0.7
<b>2001 G</b>	5	140	2.4	85	2.3
	8	100	1.7	50	1.4
	10	85	1.5	30	1.1

**Notes on effective bearing strength values**

The quasi-plastic fracture behavior of CC differs markedly from the fracture behavior of homogeneous ceramic material or that of metals. As shown in the stress-strain graph, some of the reinforcing fibers may break before the tensile strength at fracture of the whole component is reached, but such premature breaking does not lead to disastrous crack propagation or consequent total

materials failure. This „benign“ fracture behavior is also a factor in the effective bearing strength, inasmuch as the relative widening of a drillhole may amount to several percent without sudden failure of the remaining loadbearing cross-section. Indeed, the tensile stress on the remaining loadbearing cross-section often falls far short of its tensile strength at fracture, even after allowing for the notch effect of the drillholes. This notch effect roughly halves the property values given in Table 2.

**Design of components**

**Shear strength values of various SGRABOND grades in MPa**

Bolt diameter	Material grade		
	1001 G	1501 G	1601 G
8 mm	-	47	36
10 mm	22	41	51
14 mm	27	34	45

Table 10

**Notes on the shear strength of bolts**

The listed shear strength values in MPa are mean values calculated from a relatively large number of measurements. These values are defined as the first permitted material damage (see stress-strain graph – Figure 2).

As the bolts are machined from sheet, they have a privileged direction like screws, owing to the orientation of the layers. If the fabric layers are aligned in the direction of testing, they give higher measured values than those for fabric layers aligned at right angles to the test direction. The values given in the table are minimum strength values, as the fabric layers in these bolts were aligned perpendicularly to the direction of testing (Figure 14).

Figure 14

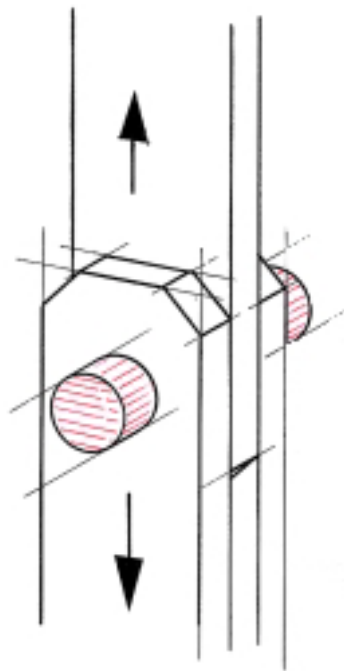

### Standard sheet dimensions

Material grade	1001 G		1501 G		1601 G
Length l [mm]			1000		
Width b [mm]			1000		
Thickness d [mm]					
	0.7 ± 0.2	1.2 ± 0.2	1.6 ± 0.2	2.5 ± 0.2	3.0 ± 0.3
	4.0 ± 0.4	5.0 ± 0.5	5.5 ± 0.5	7.5 ± 0.7	10 ± 1.0
	12.5 ± 1.1	15 ± 1.3		20 ± 2.0	30 ± 3.0

Special formats can be produced for material grades 1001 G, 1501 G and 1601 G up to 2500 mm length and 80 mm thickness.

### Standard L profiles

Material grade	1601 GS	
Length l [mm]	[mm]	1000 + 3
Side length s [mm]	[mm]	65 ± 1
Thickness d [mm]	[mm]	1.3 ± 0.2

### Standard U profiles

Material grade	1601 GS	
Length l [mm]	[mm]	1000 + 3; 2000 + 4
Side length s [mm]	[mm]	60 ± 1
Thickness d [mm]	[mm]	1.3 ± 0.2
Base width b [mm]	[mm]	20 ± 1; 30 ± 1; 40 ± 1

### Hot pressing matrices

Material grade	2001 GV				
Typical inner diameter [mm]	125	220	275	325	550
Typical wall thickness 50 mm					

### Standard pipe dimensions

Special formats can be supplied for pipes made from material grades 1501 G, 1601 G, 2001 G and 2302 G up to 1600 mm diameter and 2500 mm length.

### Forms supplied and dimensions

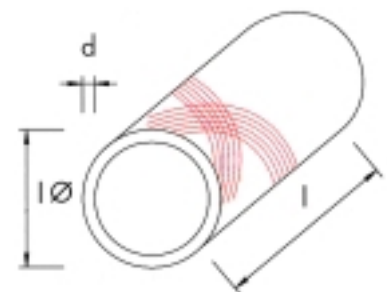
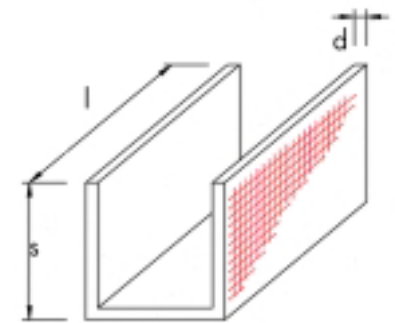
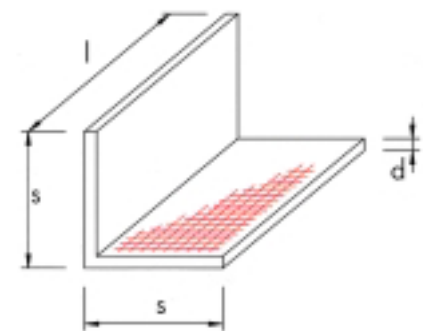
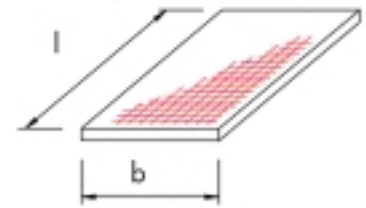

**Forms supplied  
dimensions**

**Nuts**

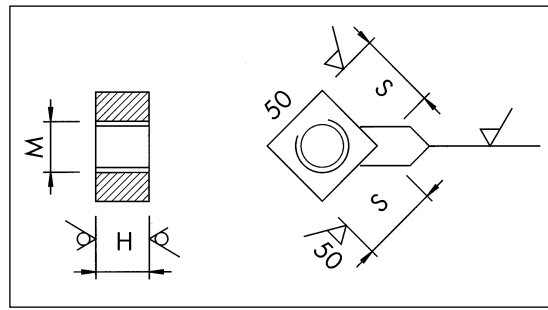

**Standards:  
M8 to M16**

**Threaded bolts**

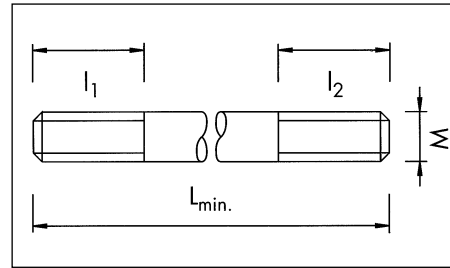

**Threaded rods**

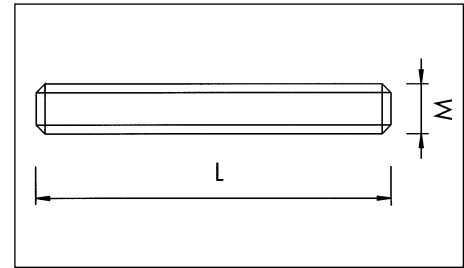

**Cheese-head  
(pan-head)  
screws**

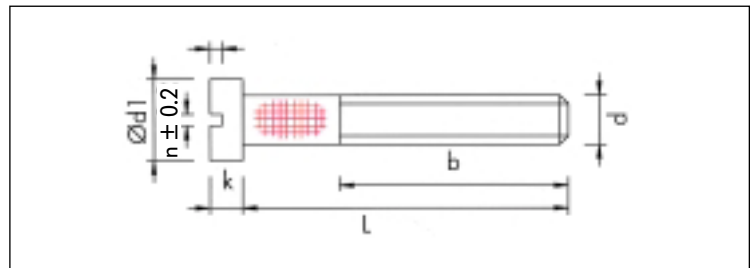

**Hammer-  
head screws**

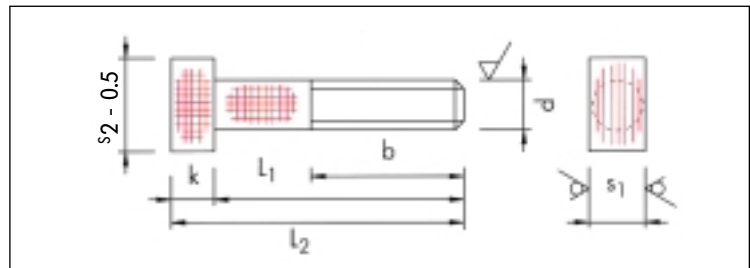

**Countersunk-  
head screws**

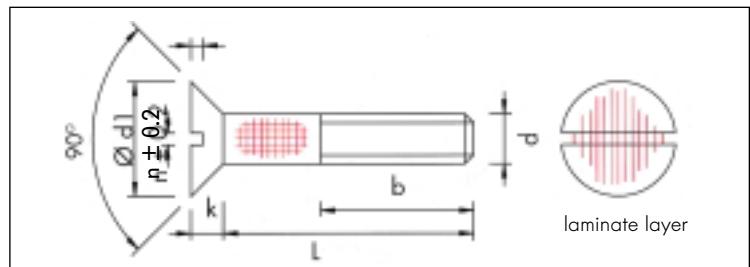

The measurements and tolerances are largely in line with the standards for metal screws. In the design of all securing elements, however, due consideration is given to the

\*SIGRABOND material's anisotropic and ceramic properties. Please ask us for our detailed drawings; special designs on request.

# Nomenclature

Example of material designation

**®SIGRABOND 1 5 O 1 G S K**

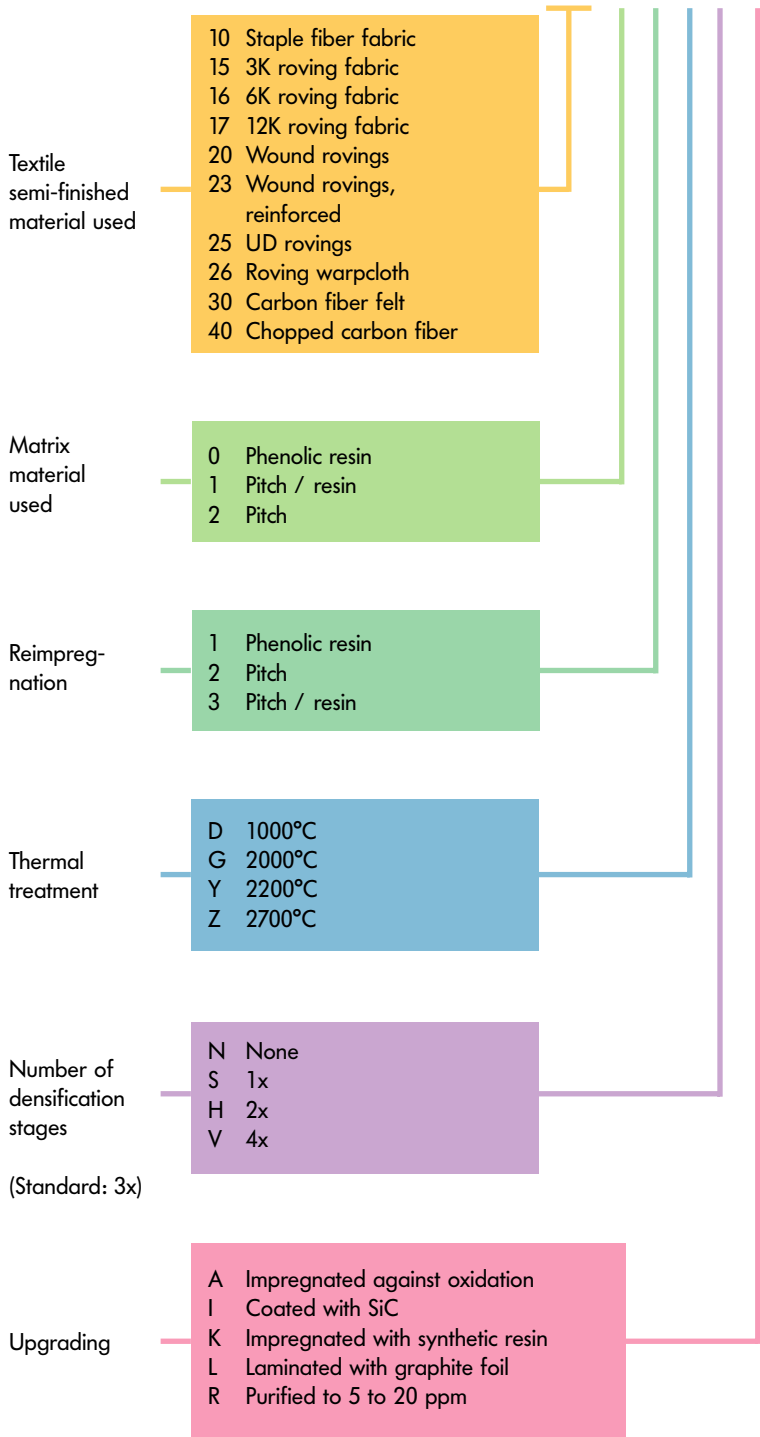

The information contained in this brochure is based on our present state of knowledge and is intended to provide general notes on our products and their uses. It should therefore not be construed as guaranteeing specific properties of the products described or their suitability for a particular application. Any existing industrial property rights must be observed. The quality of our products is guaranteed under our "General Conditions of Sale"

® registered trademark of SGL Carbon Group companies

12 2002 / 2 NÄ / Printed in Germany



**SGL CARBON GROUP**

**Graphite Specialties**

**Technical Carbon**

**SGL CARBON GmbH**

Werner-von-Siemens-Straße 18  
D-86405 Meitingen/Germany  
Phone +49 (8271) 83-2160  
Fax +49 (8271) 83-1427  
[www.sglcarbon.com](http://www.sglcarbon.com)